

Canon iR1210/1230/1270F **INSTALLATION PROCEDURE**

Go through the steps herein when installing the machine.

ENGLISH

Canon iR1210/1230/1270F INSTALLATION PROCEDURE

1 Checking the Contents

Open the shipping box, and take out the machine and accessories. Check to make sure that none of the following is missing:

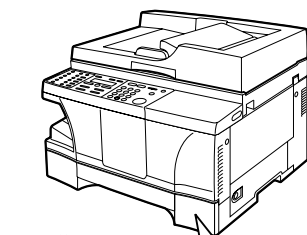

MACHINE

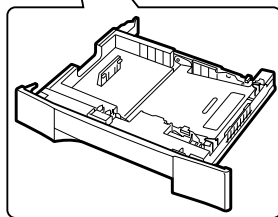

CASSETTE
(installed in the machine at the factory)

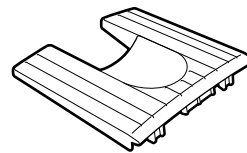

DELIVERY TRAY

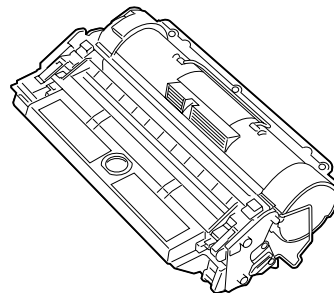

CARTRIDGE
(drum unit and developing unit)

- Power cord
- Modular cable*1
- Documentation (Quick Start Guide, Reference Guide, Fax Guide*1, Installation Procedure)
- Destination label*1
- CD-ROM

*1: Only for the iR1270F model

F1-1



Memo

The machine shown in this guide is the iR1270F model.



The toner bottle is not part of the shipment, but must be purchased separately.

2 Names of Parts

2.1 External View

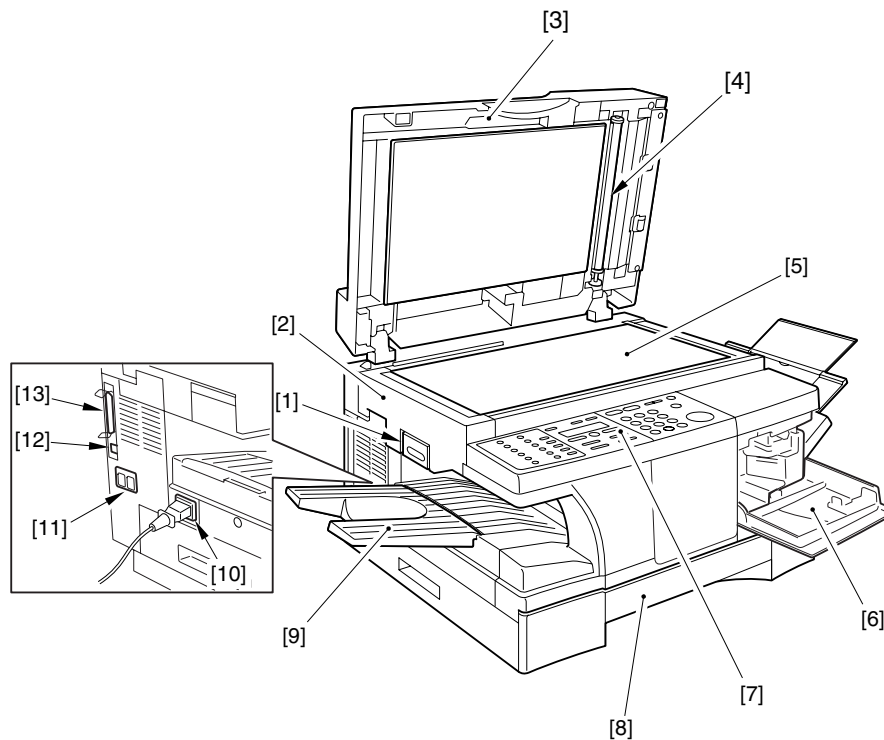

F2-1

- | | |
|-----------------------------|---|
| [1] Reader unit slide lever | [8] Cassette |
| [2] Reader unit | [9] Delivery tray |
| [3] ADF/Copyboard cover | [10] Power cord connector assembly |
| [4] White roller | [11] Modular cable connector assembly* ¹ |
| [5] Copyboard glass | [12] USB cable connector assembly |
| [6] Toner supply cover | [13] Parallel interface cable connector assembly |
| [7] Control panel | |

*1:Only for the iR1270F model.

2.2 Inside View

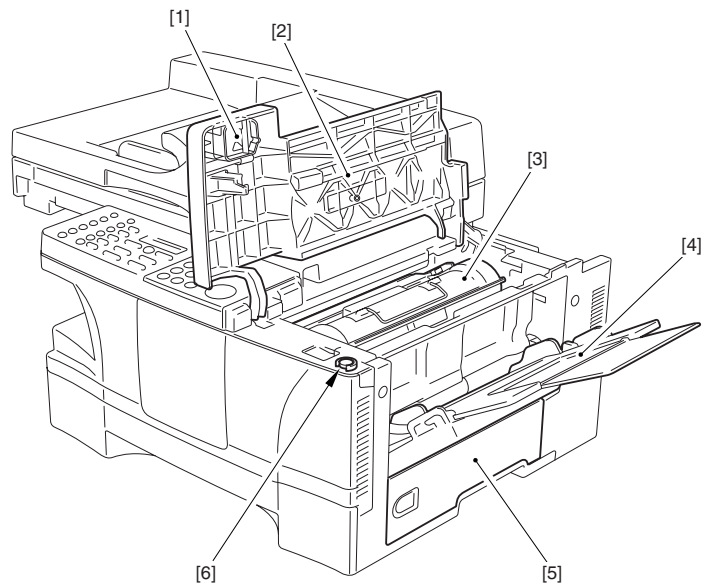

F2-2

- [1] Drum shutter stopper
- [2] Cartridge cover
- [3] Cartridge

- [4] Manual feed tray
- [5] Right door
- [6] Shipping screw slot

2.3 External View of the ADF*1

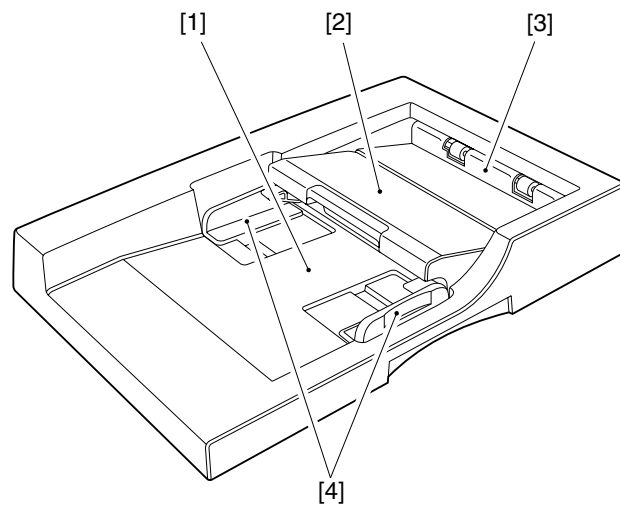

F2-3

- [1] Original placement area
- [2] Open/close cover

- [3] Delivery slot
- [4] Slide guide

*1: Only for the iR1230/1270F model.

2.4 Control Panel

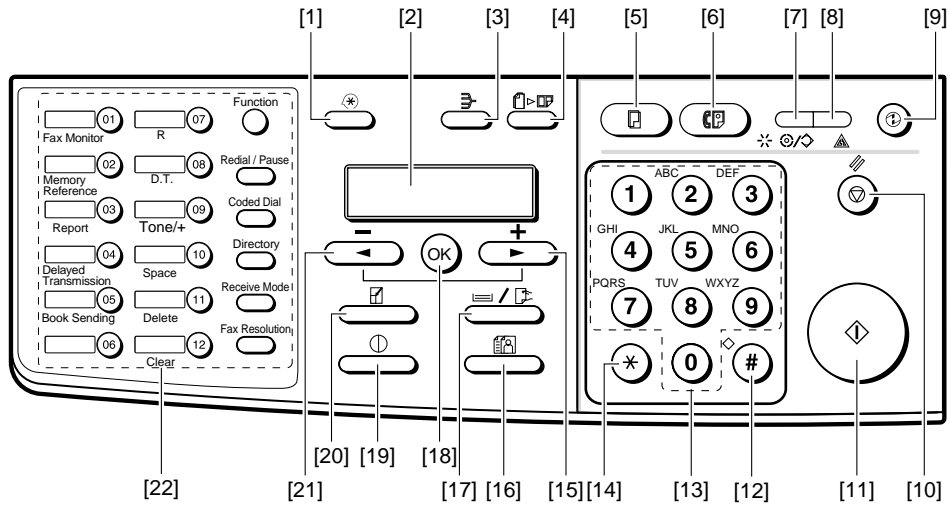

F2-4

- | | |
|--------------------------------------|---|
| [1] Additional Functions Key | [13] Keypad |
| [2] LCD | [14] * Key |
| [3] Collate Key | [15] Right Arrow/+ Key |
| [4] 2 on 1 Key | [16] Image Quality Key |
| [5] Copy Key* ¹ | [17] Paper Select Key |
| [6] Fax Key* ¹ | [18] OK Key |
| [7] In Use/Memory Lamp* ¹ | [19] Exposure Key |
| [8] Alarm Lamp | [20] Enlarge/Reduce Key |
| [9] Energy Saver Key | [21] Left Arrow/- Key |
| [10] Stop/Reset Key | [22] One-Touch/Fax Function Key (after a press on the Function key)* ¹ |
| [11] Start Key | |
| [12] # Key | |

*1:Only for the iR1270F model.

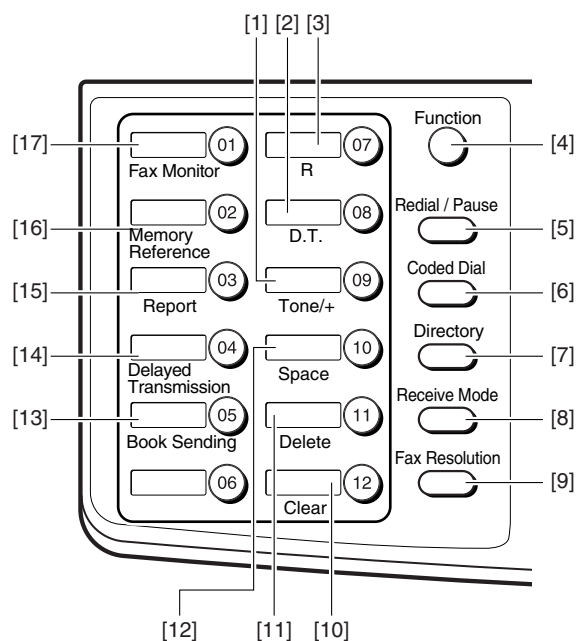

2-5

- | | |
|--------------------------------------|---|
| [1] Tone/+ Key ^{*1} | [10] Clear Key ^{*1} |
| [2] D.T. Key ^{*1} | [11] Delete Key ^{*1} |
| [3] R Key ^{*1} | [12] Space Key ^{*1} |
| [4] Function Key ^{*1} | [13] Book Send Key ^{*1} |
| [5] Redial/Pause Key ^{*2} | [14] Delayed Transmission Key ^{*1} |
| [6] Coded Dial Key ^{*2} | [15] Report Key ^{*1} |
| [7] Directly Key ^{*2} | [16] Memory Reference Key ^{*1} |
| [8] Receive Mode Key ^{*2} | [17] Fax Monitor Key ^{*1} |
| [9] FAX Resolution Key ^{*2} | |

*1:Enabled only if the machine is equipped with fax functions. Also, it is enabled only while the Function key is lit.

*2:If equipped with fax functions.

3 Point to Note Before Starting the Work

Go through the following before starting to install the machine:



If the machine is moved from a cold to a warm place for installation, condensation can develop in its pickup/feeding assembly, causing image faults. To avoid the condensation, leave the machine unpacked for 1 hr or more so that it will be fully used to the room temperature.

(The term *condensation* refers to the development of drops of water on a metal surface when it is brought from a cold to warm place. This occurs as a result of rapid cooling of vapor in the air.)

4 Unpacking

- 1) Holding the grips on the left and right of the machine, lift it out of the box.

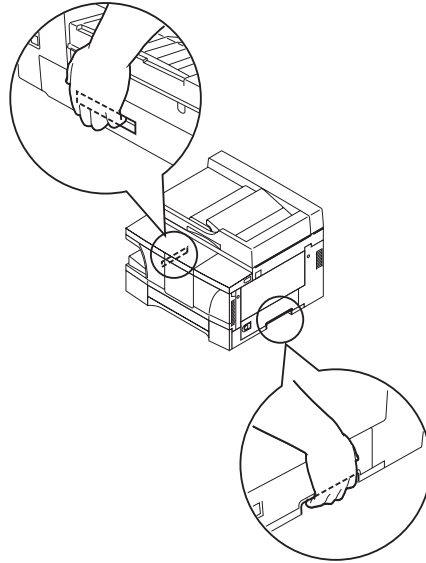

F4-1

- 2) Remove the packing material: plastic sheets, securing members, and tape.
- 3) Remove the shipping screw.

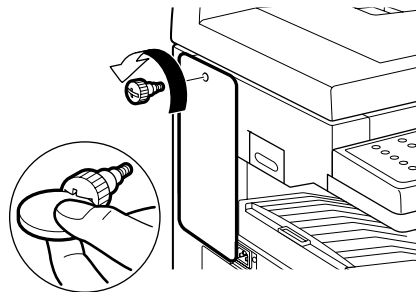

F4-2

- 4) While pulling on the reader unit slide lever, slide out the reader unit to the left.

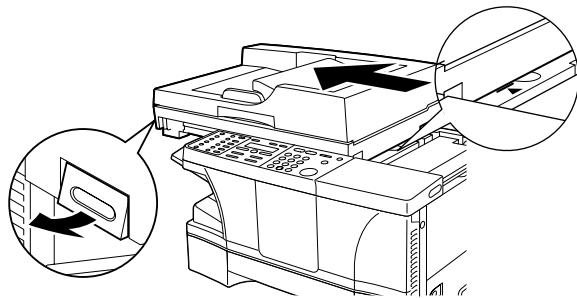

F4-3

- 5) Open the cartridge cover.

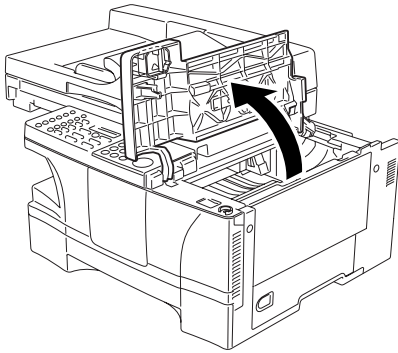

F4-4

- 6) Store away the securing member removed in step 3 in the shipping screw slot.

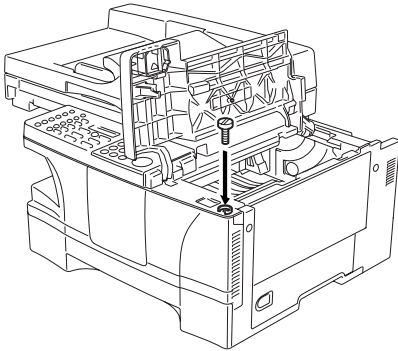

F4-5

5	Fitting the Cartridge
----------	------------------------------

- 1) Unpack the cartridge, and take it out without removing its wrappings.
- 2) Fully insert the cartridge in the direction of the arrow as indicated.

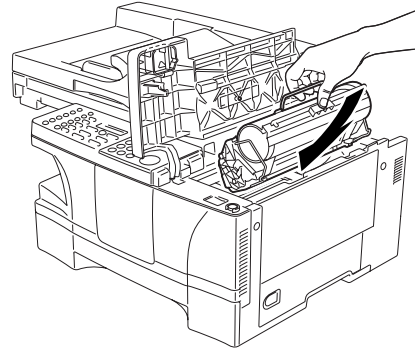

F5-1

- 3) Close the cartridge cover, and put back the reader unit.

6 Fitting the Toner bottle

- 1) Open the toner supply cover.

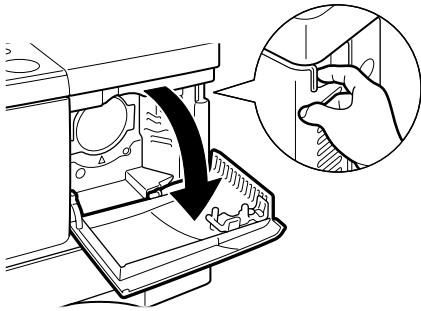

F6-1

- 2) Rock the new toner bottle five or six times to distribute the toner evenly.

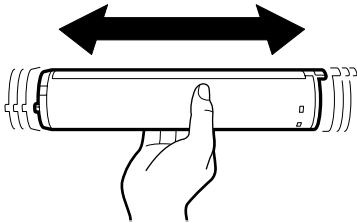

F6-2

- 3) Holding the toner bottle lever, insert the toner bottle slowly into the machine as far as it will go.

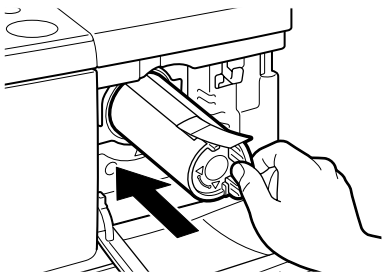

F6-3

- 4) Holding the toner bottle steady with one hand, firmly and slowly pull the sealing tape tab with the other hand to remove the sealing tape completely. Throw the tape away.

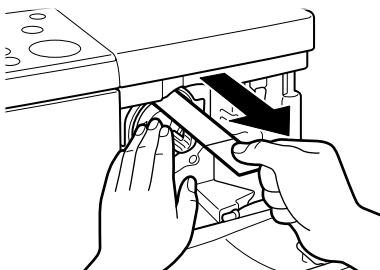

F6-4

- 5) Holding the toner bottle lever, turn it counterclockwise so that the ∇ mark on the toner bottle aligns with the Δ mark on the machine [1]. Close the toner cartridge lever [2].



Memo

If you can't turn the toner bottle, please push it into slot until stop and turn again.

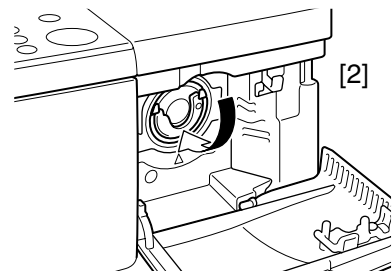
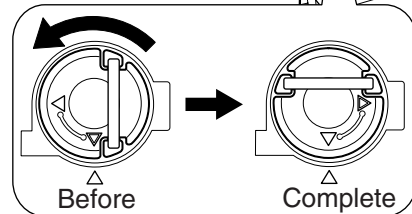
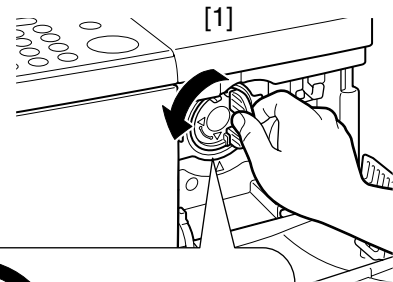

F6-5

- 6) Close the toner supply cover.

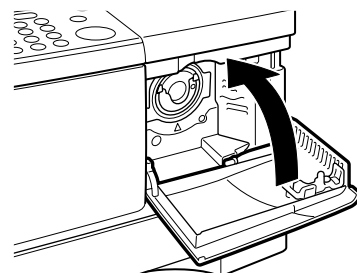

F6-6

7 Putting Paper in the Cassette

- 1) Lift the paper cassette slightly, and pull it out until it stops.

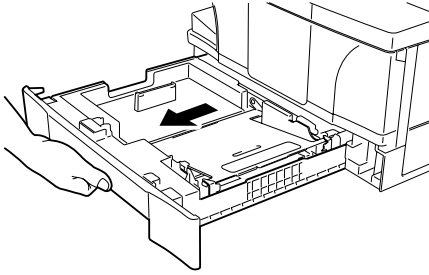

F7-1

- 2) Put paper in the cassette, under the claw must indicate what [1] and [2] are.

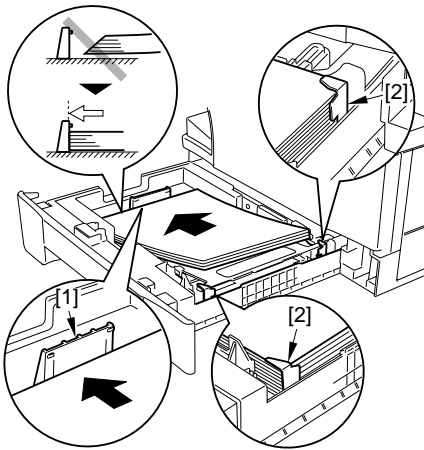

F7-2

- 3) Slide in the cassette until it stops.

8 Putting Paper in the Manual Feed Tray

- 1) Open the manual feed tray.

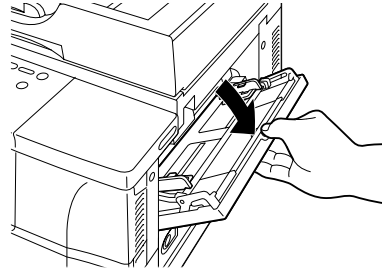

F8-1

- 2) Slid out the auxiliary tray.

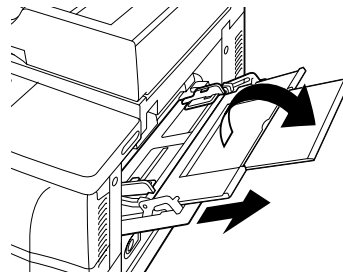

F8-2

- 3) Place the paper (with the side to be copied onto facing up).

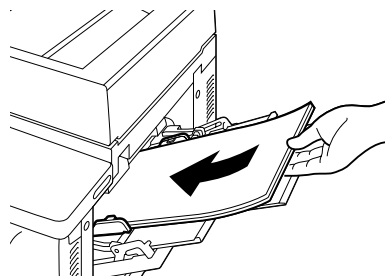

F8-3

- 4) Adjust the slide guide to suit the width of the paper.

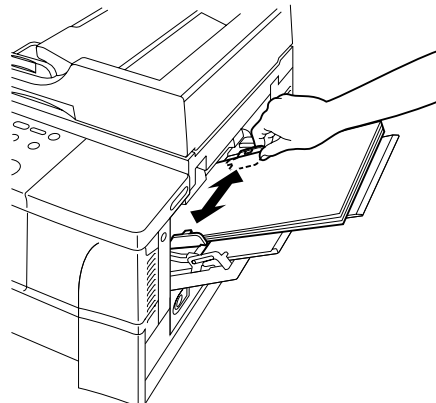

F8-4

9 Connecting the Interface Cable

- 1) Connect the cable to the USB port if a USB cable is to be used, or to the parallel port if a parallel interface cable is to be used. Be sure also to connect the cable to the PC.



Use interface cables that comply with specifications of the machine.

USB cable specifications: 5 m or shorter.

Parallel interface cable specifications: 3 m or shorter (Compliant to IEEE1284, for bi-directional communication)

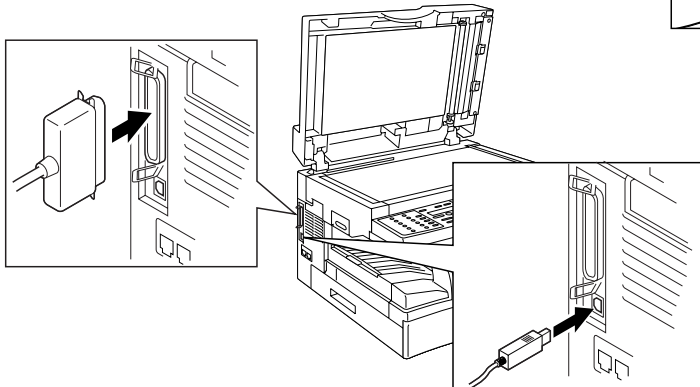

F9-1

10 Connecting the Modular Cable (Only for the iR1270F model)

- 1) Connect one end of the modular cable to the terminal [L], and the other end to the socket of the telephone.
If both telephone and fax are to be used, connect the modular cable from the telephone (or answering machine) to the [telephone] terminal.

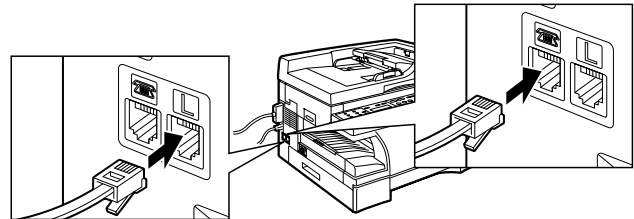

F10-1

11 Connecting the Power Cord

- 1) Connect the power cord

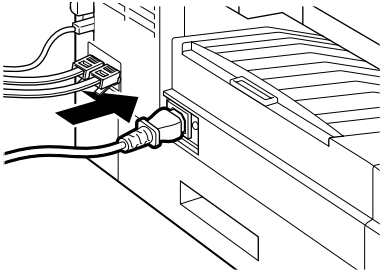

F11-1

12 Fitting the Delivery Tray

- 1) Mount the delivery tray.

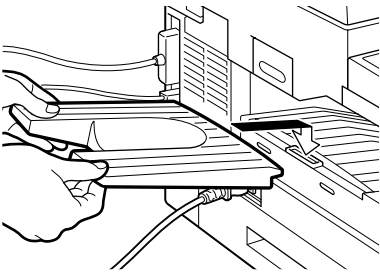

F12-1

13 Checking the Copy Images

- 1) Execute the following in user mode to stir toner: 6. ADJUST/CLEAN>4. MIX TONER.
- 2) Place an original on the copyboard glass or in the ADF and select the cassette or the manual feed tray as the source of paper; then, check the copied images.

14 Setting the Printer Functions

- 1) Install printer drivers, and perform test printing from the PC to check the images.



Be sure that the PC environment meets the requirements of the machine before installing the printer drivers.
For details, refer to Quick Start Guide.

15 Setting Fax Functions (Only for the iR1270F model)

15.1 Setting the Date/Time (user mode)

- 1) Press the Additional Functions key.
- 2) Press the Left/Right Arrow key, to select '5. TIMER SETTINGS'.
- 3) Press the OK key.
- 4) Check to make sure that '1. DATE/TIME SETTING' is indicated and press the OK key.
- 5) Enter the current date and time. Press the Left/Right Arrow key to move the cursor to the character to enter and enter a number using the keypad.
- 6) Press the OK key so that the date/time will be stored.

15-2 Setting the Dial Type

- 1) Press the Additional Functions key.
- 2) Press the Left/Right Arrow key to select '3. FAX SETTINGS'.
- 3) Press the OK key.
- 4) Check to see that '1. USER SETTINGS' is indicated and press the OK key.
- 5) Check to see that '1. TEL LINE SETTINGS' is indicated and press the OK key.
- 6) Press the Left/Right key to select '2. TEL LINE TYPE'.
- 7) Press the OK key.
- 8) Press the Left/Right key to select 'TOUCH TONE' or 'ROTARY PULSE'.
- 9) Press the OK key so that the selected line type is stored.

15-3 Executing Communications Testing

- 1) Press the Fax key in the control panel so that the machine will be in fax mode.
- 2) Try sending and receiving an original and check the operation and the images.

